



AMP-L CONDENSING BOILERS - SUBMITTAL DATA SHEET

RATINGS AND CAPACITIES		
Input - Low Fire	50,000	BTU/HR
Input - High Fire	500,000	BTU/HR
Output - High Fire	485,000	BTU/HR
Boiler Horsepower	14.5	BHP
Thermal Efficiency	97.0%	
Heating Surface	39.1	Sq.Ft.
Water Content	4.3	Gallons
Fuel	Natural Gas or LP Gas	
Firing Rate	Full Modulation	
Burner Turndown	10:1	
Low NOx Emissions	< 10 ppm	
Inlet Gas Pressure (NG)	4" wc	Min.
Inlet Gas Pressure (LP)	8" wc	Min.
	14" wc	Max.
Shipping Weight, Approximate	470	lbs

ASME Section IV (Max 160 PSIG / 210°F)	
ETL Certified to ANSI Z21.13 / CSA 4.9	
ETL Certified to UL 795 / CSA 3.1	

DIMENSIONS / CONNECTIONS		
- Height	38-1/2"	(Note 1)
- Width	26-3/8"	(Note 2)
- Length	37-3/4"	(Note 3)
- Supply Connection	2" NPT	
- Return Connection	2" NPT	
- Vent / Air Intake Connections	4"	
- Gas Connection	3/4" NPT	

STANDARD EQUIPMENT	
- ASME Stainless Steel Heat Exchanger	
- Stainless Steel Pre-Mix Burner	
- Variable Speed Combustion Blower	
- Concert Control™ (24v)	
- High Limit Temperature Control, Manual Reset	
- Water Flow Switch	
- Low Water Cutoff, Manual Reset	
- Condensate Trap	
- Blocked Condensate Switch	
- ASME Pressure Relief Valve	
- Temperature & Pressure Gauge	
- Supply & Return Temperature Sensors	
- Flue Gas Temperature Sensor	
- Modulating Gas Valve	
- Direct Spark Ignition	
- High/Low Gas Pressure Switches, Manual Reset	
- Combustion Air Switch	
- Blocked Vent Switch	
- 120 VAC Only	
- Amp Draw: 7 Amps	
- Category II and IV Venting	
- Individual or Common (Engineered) Vent System	
- CPVC, Polypropylene & Stainless Steel Acceptable *Material	
- Sealed or Room Combustion Air Intake	
- Up to 200 ft equivalent venting / air intake	

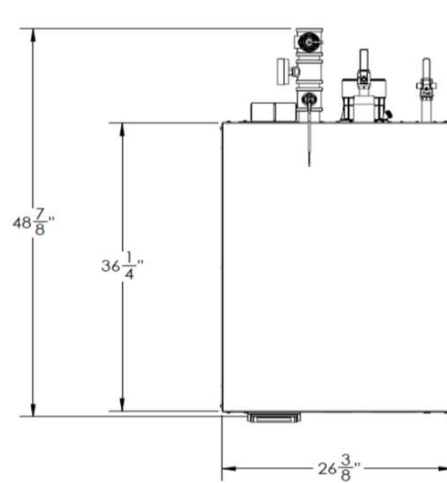

Top View

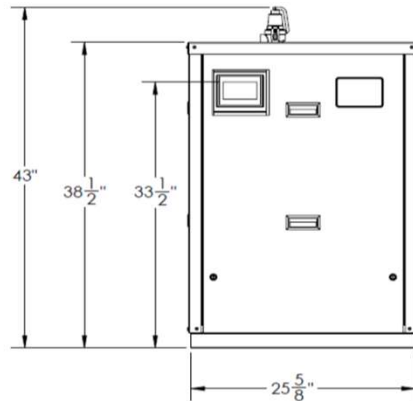

Front View

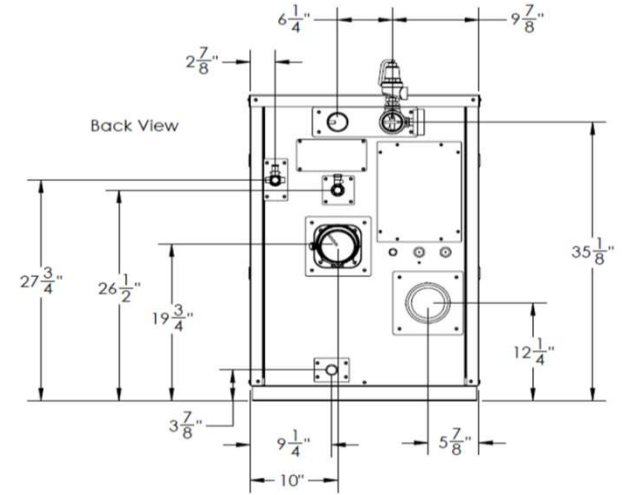

Right Side View

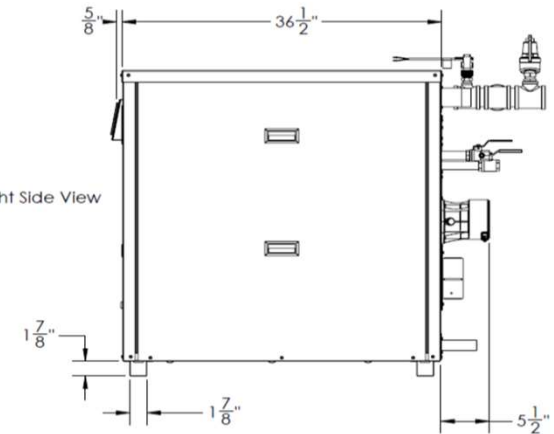

- NOTES:
1. Height dimension is from floor to top of jacket.
 2. Length is from jacket front to jacket rear.
 3. Dimensions shown are for reference only

FLOWS AND PRESSURE DROPS

Delta T	Flow (GPM)	Δ P (Ft. Hd)
20°F Δ T	49	13.7
25°F Δ T	39	9.3
30°F Δ T	32	6.7
35°F Δ T	28	5.1
40°F Δ T	24	4.1
45°F Δ T	22	3.3
50°F Δ T	19	2.7
55°F Δ T	18	2.3

AMP-500

PROPERTY OF

Manufactured Equipment for Hot Water Systems

PO BOX 3244 | LANCASTER, PA 17601

**INNOVATIVE EQUIPMENT FOR
HOT WATER SYSTEMS**

WWW.THERMALSOLUTIONS.COM

Updated 9/15/23

* Flue system material shall be capable of continuous operation at 210°F or higher and shall be certified to UL 1738 – venting system for gas-burning appliances cat II, III and IV.